

# OPERATIONAL AMPLIFIERS

What exactly is an Operational Amplifier? Let's define what that component is and look at the parameters of this amazing device. An operational amplifier IC is a solid-state integrated circuit that uses external feedback to control its functions. It is one of the most versatile devices in all of electronics.

The term 'op-amp' was originally used to describe a chain of high performance dc amplifiers that was used as a basis for the analog type computers of long ago. The very high gain op-amp IC's our days uses external feedback networks to control responses. The op-amp without any external devices is called 'open-loop' mode, referring actually to the so-called 'ideal' operational amplifier with infinite open-loop gain, input resistance, bandwidth and a zero output resistance. However, in practice no op-amp can meet these ideal characteristics. And as you will see, a little later on, there is no such thing as an ideal op-amp. Since the LM741/NE741/ $\mu$ A741 Op-Amps are the most popular one, this tutorial is direct associated with this particular type. Nowadays the 741 is a frequency compensated device and although still widely used, the Bi-polar types are low-noise and replacing the old-style op-amps.

Let's go back in time a bit and see how this device was developed. The term "operational amplifier" goes all the way back to about 1943 where this name was mentioned in a paper written by John R. Ragazzinni with the title "Analysis of Problems in Dynamics" and also covered the work of technical aid George A. Philbrick. The paper, which was defined to the work of the U.S. National Defense Research Council (1940), was published by the IRE in May 1947 and is considered a classic in electronics. It was around 1947 that the Operational Amplifier concepts were originally advanced. The very first series of modular solid-state op-amps were introduced by Burr-Brown Research Corporation and G.A. Philbrick Researches Inc. in 1962. The op-amp has been a workhorse of linear systems ever since.



At the left you see a picture of a K2-W tubes general purpose computing Op-Amp from George A. Philbrick Researches. This type was first introduced in 1952, more than a decade before the first transistorized version. The op-amp is shown with and without its bakelite shell. What a beauty! The first solid-state monolithic op-amp, designed by Bob Widlar, offered to the public in 1963 was the  $\mu$ A702 manufactured by [Fairchild](#)

[Semiconductors](#) but it had very weird supply voltages such as +12 and -6 volts and had a tendency to burn out when it was temporarily shorted. Despite all these little shortcomings this device was the best in its day. It contained just nine transistors and sold for about \$300.00 US which limited the sales to the Military and Aerospace

consumers.

In 1965 the next major change was introduced in op-amp design by Bob Widlar with the  $\mu$ A709 from Fairchild Semiconductor. It had higher gain, a larger bandwidth, lower input current, and a more user-friendly supply voltage requirement of approximately +/- 15 Volt DC. The tremendous success of the 709 was associated with high production demands causing rapid and steep price reductions. This particular op-amp, introduced at about \$70, was the first to break the \$10 barrier and again not much later the \$5 barrier. By 1969, op-amps were selling for around \$2.

The outrageous success of the  $\mu$ A709 emboldened Bob Widlar to request a significant enhancement in his compensation. When his request was denied by his boss, Charles Sporck, Widlar left Fairchild in 1966 to join the young National Semiconductor. Ironically, one year later, Sporck became president of National Semiconductors and so again becoming Widlar's boss. However, this time Sporck had to accept Widlar's compensation package, which allowed Bob Widlar to retire in 1970 just before his 30th birthday. Widlar worked briefly in 1980 for Linear Technology and continued to produce designs for National Semiconductors on a consulting basis for the rest of his life.

Under the brilliant guidance and futuristic view again of Bob Widlar, [National Semiconductor](#) decided to jump on the bandwagon with the release of a more versatile op-amp version in the form of the LM101 in 1967. It had an increased gain (up to 160K) and operation range. One of the nicest features of the LM101 was 'short-circuit' protection, and simplified frequency compensation. This was accomplished by placing an external capacitor across selected connection pins. The first op-amp to provide this internally was the hybrid LH101, which was basically a LM101 with a capacitor in a single package.

But Fairchild was not done yet. It introduced in May 1968 an internally compensated op-amp called the  $\mu$ A741. However, the differences between their LM101 and the  $\mu$ A741 were very slight. Frequency compensation is accomplished using an 'on-chip' capacitor. Offset null is accomplished by adjustment of currents in input stage emitters. On the LM101, Offset is achieved by adjusting current in input stage collectors.

In December 1968, an improved version of the LM101, the LM101A, was devised. This device provided better input control over the temperature and lower Offset currents.

National Semiconductor introduced the LM107, which had the frequency compensation capacitor built into the silicon chip. The LM107 came out at the same time as the LM101A.

In 1968, Fairchild Semiconductor issued the  $\mu$ A748. The device had essentially the same performance characteristics as the  $\mu$ A741. The difference was external frequency compensation.

The first multiple op amp device was [Raytheon Semiconductor's](#) RC4558 in 1974. Characteristics of this new device are similar to the  $\mu$ A741 except that the latter uses NPN input transistors. Later in that same year, the LM324 quad op amp from National Semiconductor became public to the delight of manufacturing industry and hobbyist alike. It is similar in characteristics in comparison with the  $\mu$ A741 in speed and input current. The LM324 is especially useful for low-power consumption. The beauty of this chip, according to some engineers, is its single-power-supply requirement.

Now the snowball was rolling. The first FET input op amp was the CA3130 made by [RCA](#). With this addition to the op-amp family, extremely low input currents were achieved. Its power can be supplied by a +5 to +15vdc single supply system. A beautiful piece of work this CA3130.

In July 1975, National Semiconductor came out with the J-FET type LF355. This was the first device created using ion implantation in an op amp.

[Texas Instruments](#) introduced the TL084 op amp in October 1976. It is a quad JFET input op amp; it also is an ion-implant JFET. Low bias current and high speed are two of its beautiful attributes.

In dated sequence, the op-amp developed like this: 1963- $\mu$ A702, 1965- $\mu$ A709, 1967-LM101/LH101, 1968- $\mu$ A741, 1974-RC4558/LM324, 1975-CA3130/LF355, and in 1976 the TL084... wow! Most of the mentioned op-amps have of course been replaced over time, keeping the same model number, with cleaner and low-noise types. Meaning, the cutting laser of the early 60's was not of the same quality and as narrow as the 70's or the 80's, etc. Other companies like RCA discontinued their semiconductor line all together.

Today, and since that month in 1976, the types of op amps have increased almost daily. We now enjoy a variety of op amps that will provide the user essentially with anything s/he needs, such as high common-mode rejection, low-input current frequency compensation, cmos, and short-circuit protection. All a designer has to do is expressing his needs and is then supplied with the correct type. Op-Amps are continually being improved, especially in the low-noise areas.

Shown in Fig.1 at the right are op-amp symbols as used today. The one on the right is an older way of drawing it but still used in books like the ARRL (American Radio Relay League) and older schematics. It is common practice to omit the power supply connections as they are implied.

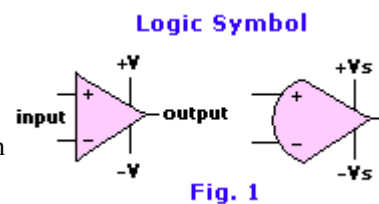

### Absolute Maximum Parameters:

**Maximum** means that the op-amp can safely tolerate the maximum ratings as given in the data section of such op-amp without the possibility of destroying it. The  $\mu$ A741 is a high performance operational amplifier with high open loop gain, internal compensation, high common mode range and exceptional temperature stability. The  $\mu$ A741 is short-circuit protected and allows for nulling of the offset

<b>Max Ratings</b>		Fig. 2
Supply voltage	$\pm 18$ Volts	
Internal Power Dissipation	500mW	
Differential Input Voltage	$\pm 30$ Volt	
Input voltage	$\pm 15$ Volt	
Voltage Offset Null/ $V_{-}$	$\pm 0.5$ Volt	
Operating Temperature Range	0° to +70°C	
Storage Temperature Range	-65° to +150°C	
Lead Temperature, Solder, 60sec.	300°C	
Output Short Circuit	Indefinite	

voltage. The  $\mu$ A741 is Manufactured by Fairchild Semiconductor.

**Supply Voltage (+/-Vs):** The maximum voltage (positive and negative) that can be safely used to feed the op-amp.

**Dissipation ( $P_D$ ):** The maximum power the op-amp is able to dissipate, by specified

ambient temperature (500mW @ 80° C).

**Differential Input Voltage ( $V_{id}$ ):** This is the maximum voltage that can be applied across the + and - inputs.

**Input Voltage ( $V_{icm}$ ):** The maximum input voltage that can be simultaneously applied between both input and ground also referred to as the common-mode voltage. In general, the maximum voltage is equal to the supply voltage.

**Operating Temperature ( $T_a$ ):** This is the ambient temperature range for which the op-amp will operate within the manufacturer's specifications. Note that the military grade version ( $\mu A741$ ) has a wider temperature range than the commercial, or hobbyist, grade version ( $\mu A741C$ ).

**Output Short-Circuit Duration:** This is the amount of time that an op-amp's output can be short-circuited to either supply voltage.

### Summed-up Features:

Internal Frequency Compensation  
Short Circuit Protection  
Offset voltage null capability  
Excellent temperature stability  
High input voltage range  
NO latch-up

### Input Parameters:

1. **Input Offset Voltage ( $V_{oi}$ )**  
This is the voltage that must be applied to one of the input pins to give a zero output voltage. Remember, for an ideal op-amp, output offset voltage is zero!
2. **Input Bias Current ( $I_b$ )**  
This is the average of the currents flowing into both inputs. Ideally, the two input bias currents are equal.
3. **Input Offset Current ( $I_{os}$ )**  
This is the difference of the two input bias currents when the output voltage is zero.
4. **Input Voltage Range ( $V_{cm}$ )**  
The range of the common-mode input voltage (i.e. the voltage common to both inputs and ground).
5. **Input Resistance ( $Z_i$ )**  
The resistance 'looking-in' at either input with the remaining input grounded.

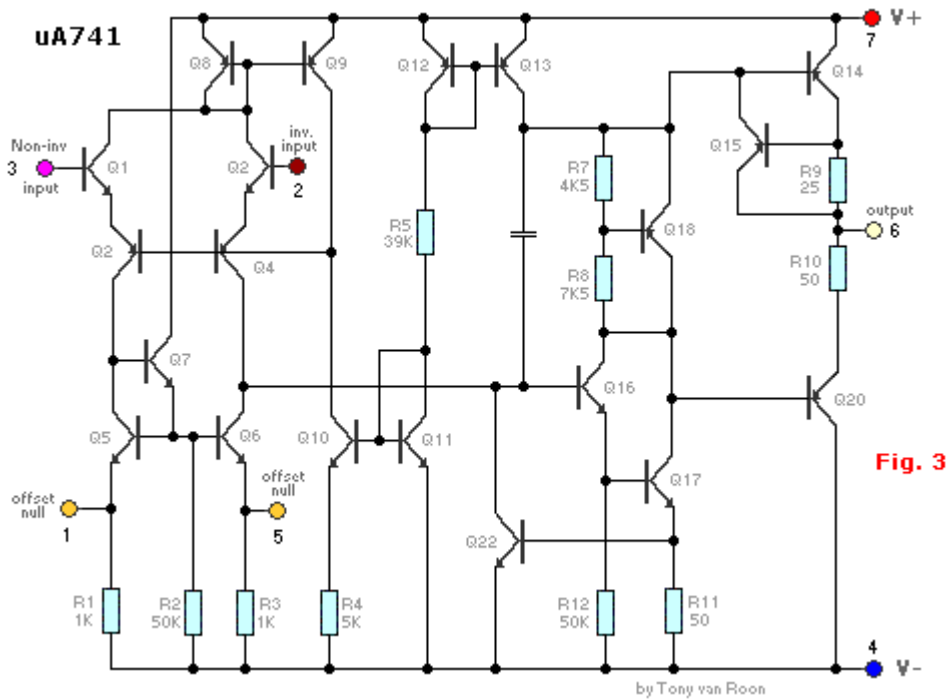

**Fig. 3**

### Output Parameters:

1. **Output Resistance ( $Z_{oi}$ )**  
The resistance seen 'looking into' the op-amp's output.
2. **Output Short-Circuit Current ( $I_{osc}$ )**  
This is the maximum output current that the op-amp can deliver to a load.
3. **Output Voltage Swing ( $V_o \text{ max}$ )**  
Depending on what the load resistance is, this is the maximum 'peak' output voltage that the op-amp can supply without saturation or clipping.

### Dynamic Parameters:

1. **Open-Loop Voltage Gain ( $A_{ol}$ )**  
The output to input voltage ratio of the op-amp without external feedback.
2. **Large-Signal Voltage Gain**  
This is the ratio of the maximum voltage swing to the change in the input voltage required to drive the output from zero to a specified voltage (e.g. 10 volts).
3. **Slew Rate (SR)**  
The time rate of change of the output voltage with the op-amp circuit having a voltage gain of unity (1.0).

### Other Parameters:

1. **Supply Current**  
This is the current that the op-amp will draw from the power supply.
2. **Common-Mode Rejection Ratio (CMRR)**  
A measure of the ability of the op-amp' to reject signals that are

simultaneously present at both inputs. It is the ratio of the common-mode input voltage to the generated output voltage, usually expressed in decibels (dB).

### 3. Channel Separation

Whenever there is more than one op-amp in a single package, like the 747 op-amp, a certain amount of "crosstalk" will be present. That is, a signal applied to the input of one section of a dual op-amp will produce a finite output signal in the remaining section, even though there is no input signal applied to the unused section.

#### Open-Loop Gain & Frequency:

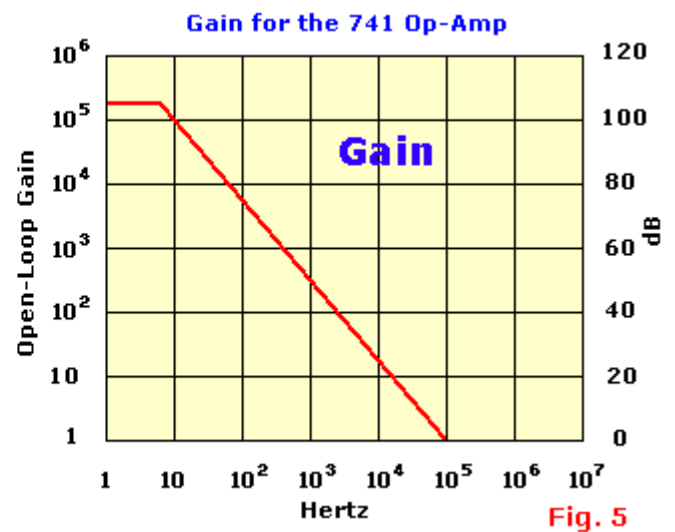
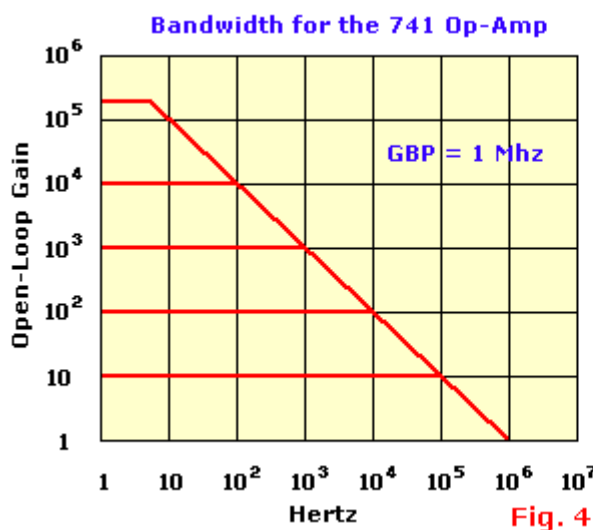

Unlike the ideal op-amp (Fig. 5-1), the op-amp that is used in more realistic circuits today, does not have infinite gain and bandwidth. Look at Open-loop gain in Fig. 4 above, it is graphed for a type 741 op-amp as a function of frequency. At very low frequencies, the open-loop gain of an op-amp is constant, but starts to taper off at about 6Hz or so at a rate of -6dB/octave or -20dB/decade (*an octave is a doubling in frequency, and a decade is a ten-fold increase in frequency*). This decrease continues until the gain is unity, or 0 dB. The frequency at which the gain is unity is called the unity gain frequency or  $f_T$ . Maybe the first factor in the consideration of a specific op-amp is its "gain-bandwidth product" or **GBP**. For the response curve of Fig. 4, *the product of the open-loop gain and frequency is a constant at any point on the curve*, so that:  $GBP = A_0BW$

Graphically, the bandwidth is the point at which the closed-loop gain curve intersects the open-loop curve, as shown in Fig. 5 for a family of closed-loop gains. For a more practical design situation, the actual design of an op-amp circuit should be approximately 1/10 to 1/20 of the open-loop gain at a given frequency. This ensures that the op-amp will function properly without distortion. As an example, using the response in Fig. 4, the closed-loop gain at 10Khz should be about 5 to 10, since the open-loop gain is 100 (40dB). One additional parameter is worth mentioning, the **Transient Response, or rise time** is the time that it takes for the output signal to go from 10% to 90% of its final value when a step-function pulse is used as an input

signal, and is specified under close-loop conditions. From electronic circuit theory, the rise time is related to the bandwidth of the op-amp by the relation:  $BW = 0.35 / \text{rise time}$

### Open-Loop Gain:

Lets have a look how the 'ideal' amplifier would look like in Fig. 5-1. The search for an ideal amplifier is, of course, a futile exercise. The characteristics of the operational amplifier are good enough, however, to allow us to *treat* it as ideal. Below are some amplifier properties that make this so. (Please realize that these ratings are next to impossible to achieve).

1. Gain--infinite
2. Input impedance--infinite
3. Output impedance--zero
4. Bandwidth--infinite
5. Voltage out--zero (when voltages into each other are equal)
6. Current entering the amp at either terminal--extremely small

### The Ideal Amplifier

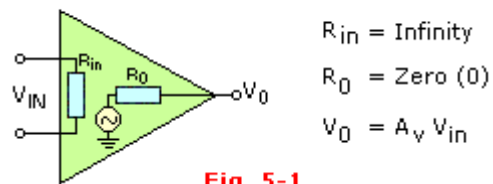

Fig. 5-1

### Power Supply:

In general op-amps are designed to be powered from a dual or bipolar voltage supply which is typically in the range of +5V to +15Vdc *with respect to ground*, and another supply voltage of -5V to -15Vdc with respect to ground, as shown in Fig. 7. Although in certain cases an op-amp, like the LM3900 and called a 'Norton Op-Amp', may be powered from a single supply voltage.

### Electrical Ratings:

Electrical characteristics for op-amps are usually specified for a certain (given) supply voltage and ambient temperature. Also, other factors may play an important role such as certain load and/or source resistance. In general, all parameters have a typical minimum/maximum value in most cases.

Fig. 6 - The two most common types are shown in the diagram on the right.

Depending on the application, the 8-pin version is

used the most, worldwide. Actually, there is a third type in the form of a metal-can but is obsolete and, by my knowledge, no longer used. I have two of these metal-can types and keep them as a 'gone-by' memory.

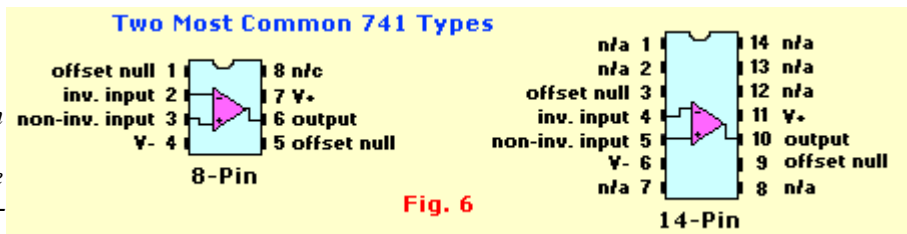

Fig. 6

**Definition of 741-pin functions:** (Refer to the internal 741 schematic of Fig. 3)

**Pin 1 (Offset Null):** Offset nulling, see Fig. 11. Since the op-amp is the differential type, input offset voltage must be controlled so as to minimize offset. Offset voltage is nulled by application of a voltage of opposite polarity to the offset. An offset null-adjustment potentiometer may be used to compensate for offset voltage. The null-offset potentiometer also compensates for irregularities in the operational amplifier manufacturing process which may cause an offset. Consequently, the null potentiometer is recommended for critical applications. See 'Offset Null Adjustment' for method.

**Pin 2 (Inverted Input):** All input signals at this pin will be inverted at output pin 6. Pins 2 and 3 are very important (obviously) to get the correct input signals or the op amp can not do its work.

**Pin 3 (Non-Inverted Input):** All input signals at this pin will be processed normally without inversion. The rest is the same as pin 2.

**Pin 4 (-V):** The V- pin (also referred to as V<sub>SS</sub>) is the negative supply voltage terminal. Supply-voltage operating range for the 741 is -4.5 volts (minimum) to -18 volts (max), and it is specified for operation between -5 and -15 Vdc. The device will operate essentially the same over this range of voltages without change in timing period. Sensitivity of time interval to supply voltage change is low, typically 0.1% per volt. (Note: Do not confuse the -V with ground).

**Pin 5 (Offset Null):** See pin 1, and Fig. 11.

**Pin 6 (Output):** Output signal's polarity will be the opposite of the input's when this signal is applied to the op-amp's inverting input. For example, a sine-wave at the inverting input will output a square-wave in the case of an inverting comparator circuit.

**Pin 7 (posV):** The V+ pin (also referred to as V<sub>CC</sub>) is the positive supply voltage terminal of the 741 Op-Amp IC. Supply-voltage operating range for the 741 is +4.5 volts (minimum) to +18 volts (maximum), and it is specified for operation between +5 and +15 Vdc. The device will operate essentially the same over this range of voltages without change in timing period. Actually, the most significant operational difference is the output drive capability, which increases for both current and voltage range as the supply voltage is increased. Sensitivity of time interval to supply voltage change is low, typically 0.1% per volt.

**Pin 8 (N/C):** The 'N/C' stands for 'Not Connected'. There is no other explanation. There is nothing connected to this pin, it is just there to make it a standard 8-pin package.

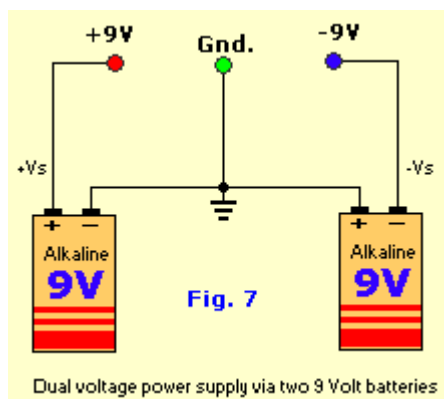

### Experiments:

You are given the opportunity to play with and analyze experiments to demonstrate the principles, concepts, and applications of a couple of these basic configured op-amps.

If you have already a dual-voltage power supply (positive/negative), that would make things a lot

easier for you. If not, build this **Dual Volt Powersupply** listed at the bottom of the page to get you started. This power supply has two non-adjustable voltages; +12Vdc and -12Vdc. However, in general, a very simple and cheap power supply can be rigged up with two 9 Volt alkaline batteries and does the job in most, if not all, cases. Personally I like to approach a project more professionally and build the dual 12 volt powersupply. Nice project 'in-between' while learning op-amps.

### Bread Board Modules:

A bread board module, or just 'breadboard', is a board manufactured of plastic with a couple 100 tiny holes with tiny sockets in them connected electrically together and in the center of the breadboard a groove to hold a plastic panel for leds, pots and switches. They measure about 6 by 2 inches and come in white, gray and blue. The blue kind is called 'BimBoard' and made in the UK. I purchased mine back in 1980 from [ElectroSonic](#) in Toronto Canada and its still working fine. The gray and white models are manufactured in the U.S. and Canada. They all work.

Radio Shack and the European Tandy are both selling their own version and they work fine too.

The Bread Board Design System is also available, if you can afford it, and would be preferred if you intend to do a lot more experimenting in the future. This system contains everything you need already build-in, like the powersupply, jacks, switches, leds, function generator and lots more goodies. Kindah nice to have everything in one place.

### The Norton Op-Amp:

It is not my intention to confuse you with a different type of op-amp so I will just mention a couple of points about this op-amp. The Norton op-amp, or current-differencing amplifier, is designed to operate from a single ended supply.

Wow, that is truly fantastic. You can use a voltage anywhere from +4V to a whopping +36V! The Norton op-amp referred to here is the LM3900 and is the best known type made

by National Semiconductor. This chip contains four op-amps in a single 14-pin package. The picture in Fig. 8-b below shows the symbol for the Norton op-amp. As you may notice it is

somewhat different than the normal op-amp symbol. Fig.

8-c shows the major parameters of relevance between the 741 and the 3900 op-amps.

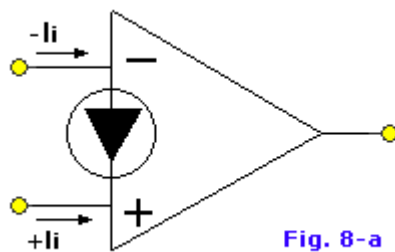
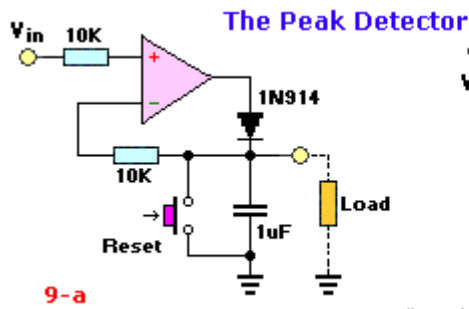
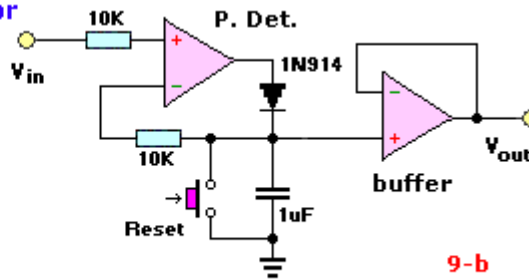

Fig. 8-a

Fig. 8-b	741	3900
Supply Voltage, V	+15	+4 to+36
Gain, Open Loop	200,000	2800
$f_{t1}$ , Mhz	1.0	1.0
$I_{b1}$ , uA	80	30
$Z_1$ , M-ohm	2.0	1.0
$Z_0$ , ohm	75	8 K
Slew Rate, V/uSec	0.5	0.5



Courtesy SAMS, "Design of op-amps with experiments"



**The Peak Detector**  
or  
The peak detector is a circuit that

"remembers" the peak value of a signal. As shown in Fig. 9-a, when a *positive* voltage is fed to the noninverting input after the capacitor has been momentarily shorted (reset), the output voltage of the op-amp forward biases the diode and charges up the capacitor. This charging lasts until the inverting and noninverting inputs are at the same voltage, which is equal to the input voltage. When the noninverting input voltage exceeds the voltage at the inverting input, which is also the voltage across the capacitor, the capacitor will charge up to the new peak value. Consequently, the

capacitor voltage will always be equal to the greatest positive input.

the voltage applied to the noninverting

Once charged, the time that the peak detector "remembers" this peak value is typically several minutes and depends on the impedance of the load that is connected to the circuit. Consequently, the capacitor will slowly discharge towards zero. To minimize this rate of discharge, a voltage follower can be used to buffer the detector's output from any external load, as shown in Fig. 9-b. Momentarily shorting the capacitor to ground will immediately set the output to zero.

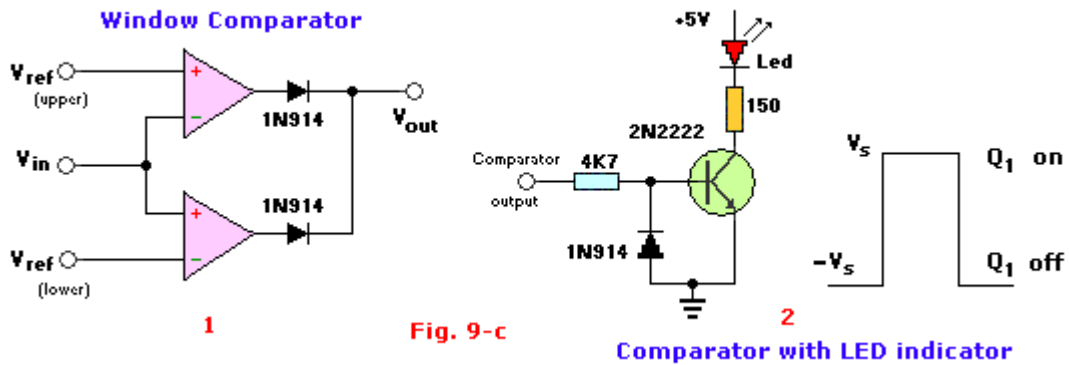

### The Comparator

A 'comparator' is a circuit that compares an input voltage with a reference voltage.

The output of the comparator then indicates whether the input signal is either above or below the reference voltage. As shown for the basic circuit in Fig. 9-c(1), the output voltage approaches the positive supply voltage when the input signal is slightly greater than

the reference voltage,  $V_{ref}$ . When the input is slightly less than the reference, the op-amp's output approaches the negative supply voltage. Consequently, the exact threshold is dominated by the op-amp's input offset voltage, which should be nulled out. Fig. 9-c(2) shows a Led indicator wch input is connected to the output  $V_{out}$  of the comparator.

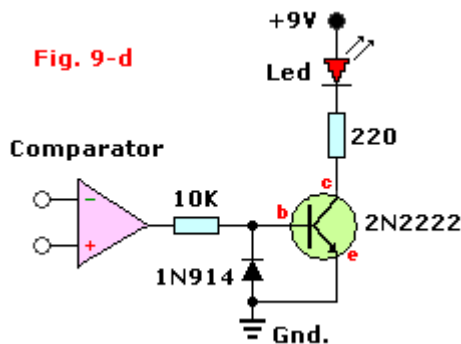
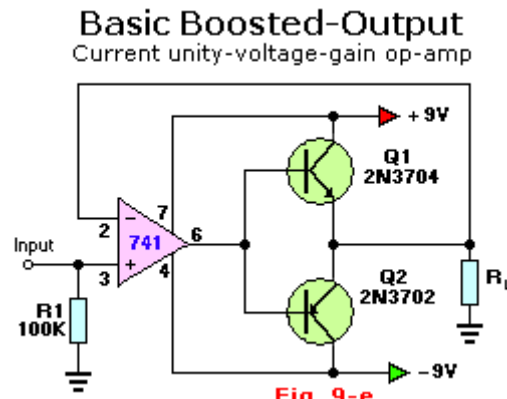

Fig. 9-d

Comparator



Basic Boosted-Output  
Current unity-voltage-gain op-amp

Fig. 9-e

Fig. 9-d

(left)  
The output polarity of the op-amp switch

es from positive to negative, it is inconvenient to keep reversing the voltmeter leads to keep polarity correct. One way to overcome that problem is to use an indicator light to tell the output state. The circuit show on the left uses a transistor to switch a led on or off depending on the comparator's output state. When the op-amp output is 8.5 volts, the transistor switches on the led via the 220 ohm current-limiting resistor. When the output is -8.5 volts the transistor is cut-off turning off the led. Transistor choice is not critical; it can be any common type NPN device. Any type of silicon diode will protect the transistor. Fig. 9-e(right). The output on pin 6 switches (repeatedly) from positive to negative and so either bias Q1 (NPN) or Q2 (PNP and activates  $R_L$  which is the resistive load. Just a basic circuit to show you what exactly a 'Boosted-Output' circuit does.

### The Instrumentation Amplifier

There are many types of op-amps who are designed for a specific purpose like the Instrumentation Amplifier from Burr-Brown.(see Fig. 10) In this example we are

talking about the 3660J type. It can be used in both balanced and unbalanced systems, like a Wheastone Bridge circuit. This does not

mean in any way that the instrumentation amp cannot be used for other applications, on the contrary, it is in many a case preferred because of the unique parameters of this device.

**Keep this in mind as a rule-of-thumb:**

An operational amplifier circuit will not work *at all* unless:

1. External feedback limits the gain or desired response to a design value.
2. Both inputs have direct-current return path to ground of a similar reference.
3. The input frequencies and required gain are well within the performance limitations of the op-amp used.

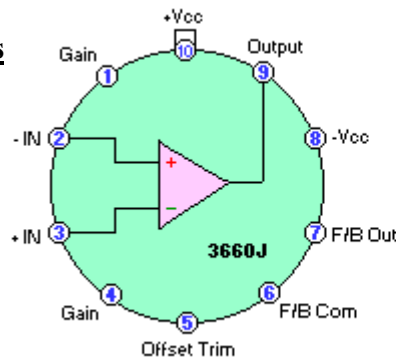

**IA Difference Amplifier**

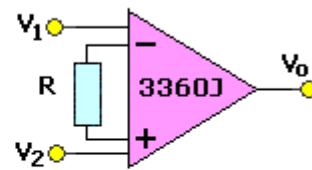

**The Burr-Brown Instrumentation Amplifier**

**Fig. 10**

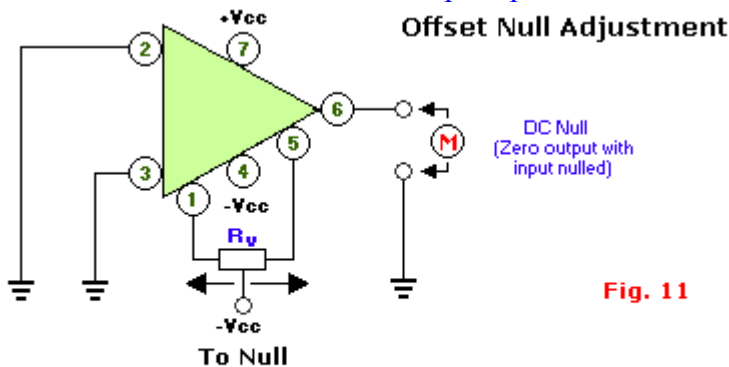

**Fig. 11**

**Offset Null Adjustment Procedure for the  $\mu A741$ :**

Offset null adjustments differ with the application (e.i. Inverting or Non-Inverting Amplifier).

Note: Both inputs grounded as shown above implies that  $V_{in}$  is zero and that each input has a DC resistance path to ground. The actual resistance depends on the application.

Offset-null potentiometers are *not* placed on design schematics as they would detract from a design. For practice, perform the following Offset Null adjustment if you wish:

1. Adjust the 10K pot(entio)meter to its center position.
2. Connect the potmeter outside leads between pins 1 and 5 of the op-amp. Make sure that the power is applied to the design application.
3. Connect the wiper of the potmeter to the negative supply voltage.
4. Ensure that input signals are zero or null and that pins 2 and 3 have a dc return to ground.
5. Measure the output with a dc meter and obtain zero null by adjusting the potentiometer.

*This is just one method and recommended nulling procedure for the  $\mu A741$  type op-amp. Always look for, and follow the particular procedure as specified by that chip manufacturer. Procedures may become obsolete or updated and changed when improved op-amp versions come on the market.*

**Planning Your Prototype or Experiment:**

Planning the layout of your experiments could be important, especially with large circuits. Use this [\[lay-out sheet\]](#) to plan your components layout on the bread board, if

you wish. Remove every component and all wires from previous experiments.  
**Important:** Before starting to insert components into the breadboard, make sure all power and signal connections are removed and the power source disconnected. And if required, take the glue/dirt of the components' legs before inserting them into the sockets, it is very hard if not impossible to get it cleaned out.

### **A couple circuit examples:**

Below are a couple circuit examples you can play and experiment with to understand the working of a 741 op-amp hands on. If you are serious about electronics I strongly recommend buying a book or two about Op-Amps for your experimenting pleasures.

### **Fig. 12 - Light Sensor**

This is a really nice circuit to play with. When there is NO light falling on the sensor, the relay closes. When light falls on the LDR, the relay opens. To reverse the situation just exchange LDR and R1. Example uses for this circuit: Dark-room, Automatic door-lock, closet, Shed Alarm, etc.

### **Fig. 13 - Smart Continuity Tester**

Occasionally you need a continuity test between two points in an electronic circuit.

Unfortunately, most continuity testers are prone to "lie". They don't do that deliberately, but if they see a small resistance, they *still* tell you that you have continuity. They just don't know any better. This unit is different. If you have continuity it will tell you so. And if you're reading even a low resistance through a component, the unit will tell you that as well. The unit uses two 741 op-amps. It offers a short-circuit test current of less than 200uA. It detects resistance values of less than 10 ohms. Nicest of all, it will not break down a PN junction. The device has come in handy in my own shop for debugging electronic circuits.

### **Fig. 14 - 12V Battery Monitor**

The 100 Kilo-ohm trimmer pot controls the set point of this circuit to a 'high' point like 12.5 or something, so adjust it to the point you wish the LED to light up. To monitor a 'low' point, and have the led light up when the battery has drained to a certain point, connect the led (via the 330 ohm resistor) to ground (in the blue-boxed area). The led is the high-brightness or ultra-bright type for maximum visibility. The trimpot in the schematic is a 10-turn type for better accuracy, but basically any type will do.

### **Fig. 15 - Low Power Amplifier**

This is a simple low power amplifier with a single powersupply. The Rx resistor + the resistance of the speaker should equal 1000 ohm. Example: speaker is 150 ohm. Rx is  $1000 - 150 = 850$  ohm. Closest available value is 860 ohm. I know what your thinking; what about the 30 volt? Is'nt the max 15 volt? Yes, but positive and negative they combine 30 volt.

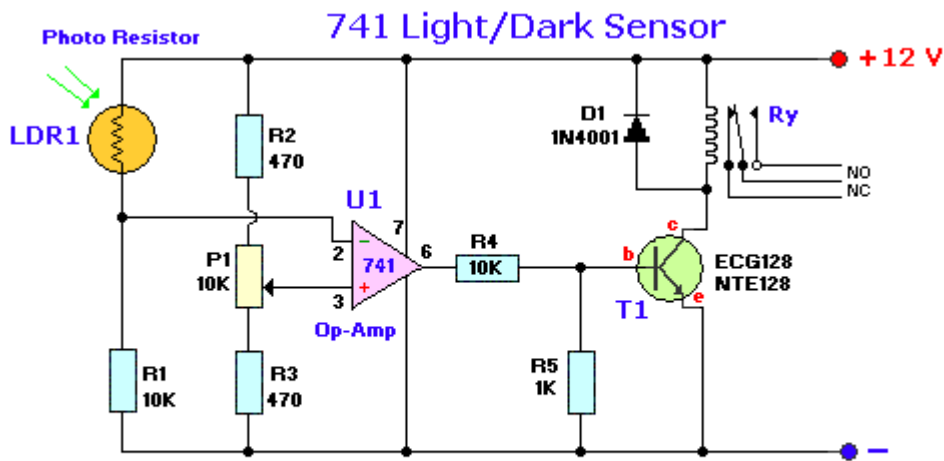

- Relay closes when no light falls on LDR1
- For reversed action, exchange LDR1 and R1
- Sensitivity can be adjusted with P1
- D1 prevents sparking of relay-coil when it opens

Fig. 12

### Smart Continuity Tester

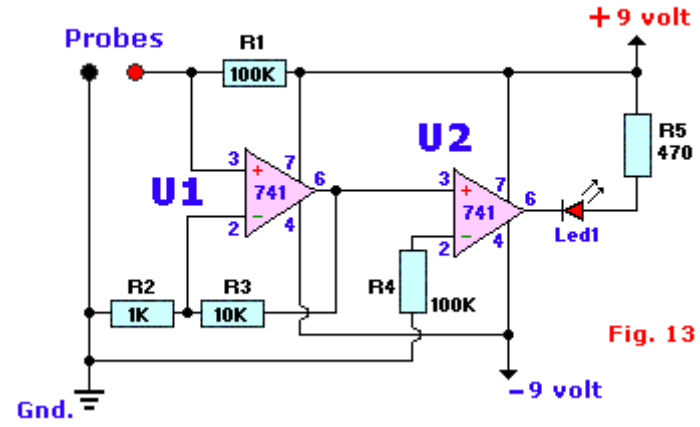

Fig. 13

### 12V Battery Monitor

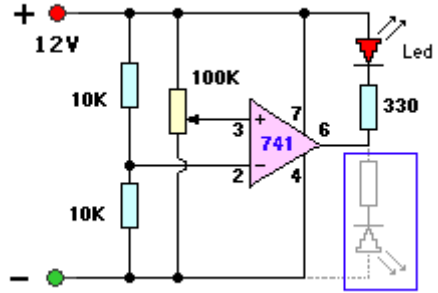

Fig. 14

## Low-Power Amplifier

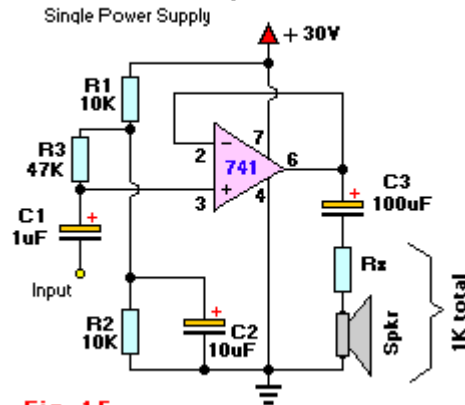
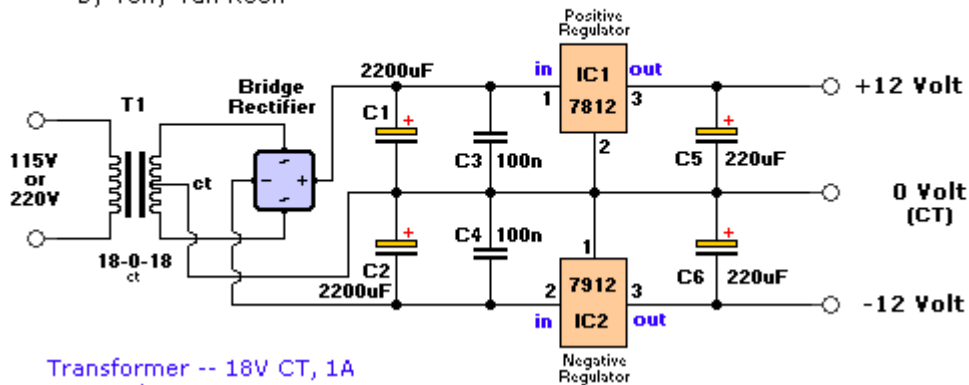

Fig. 15

Below is the Dual Volt Power Supply to power the op-amps. Check the output voltages when you are done. You may lower the 220 $\mu$ F caps to 100 $\mu$ F if need be.

## Dual Voltage Power Supply

by Tony van Roon



Transformer -- 18V CT, 1A  
 Capacitors -- 35V  
 Bridge Rectifier -- 100V, 2A  
 C3,C4 -- Ceramic, 50V

Caution: Input/Ground are reversed between the 7812 and 7912.

Pos. Reg.

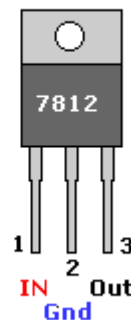

Neg. Reg.

